

Single Tank Automatic

SHOWER SOFTENING UNITS



Single tank automatic shower softening units feature:

- Can accept hot water up to 167°F
- Water leakage protection probe that turns the control valve to bypass position when water leak is detected
- Intelligent automatic regeneration and low salt alarm
- Two regeneration options, conventional and economical with soak status, increasing treatment capacity by 20%
- Inlet water TDS detection probe can be installed for automatic water treatment capacity conversion



M8A3



M8B3

Single Tank Automatic

SHOWER SOFTENING UNITS

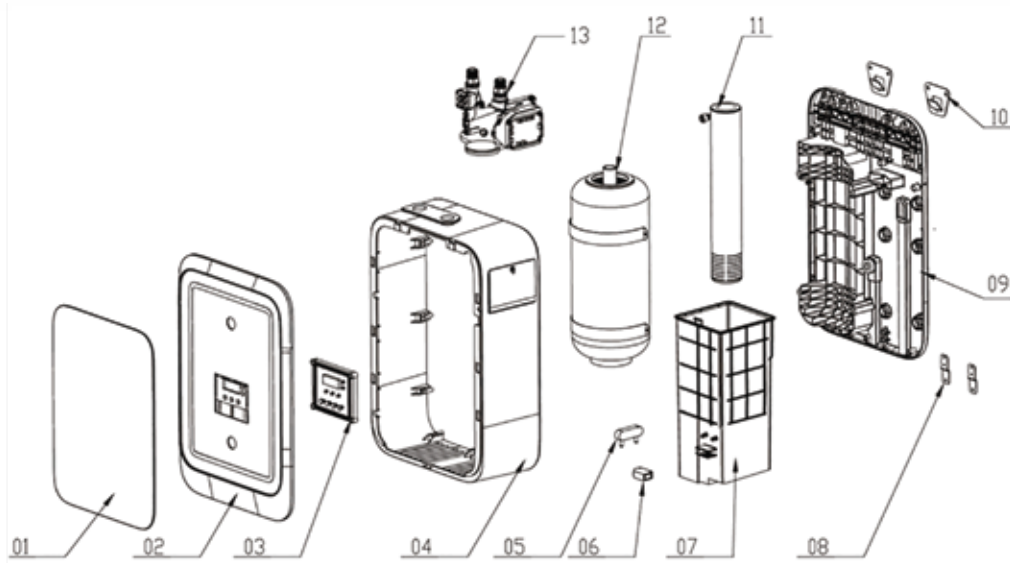

- 01. Glass panel
- 02. Front shell
- 03. Display board
- 04. Middle shell
- 05. Water leakage monitoring sensor
- 06. Salt level monitoring sensor
- 07. Brine tank
- 08. Fixed monopod
- 09. Behind shell
- 10. Hanging board
- 11. Brine well and brine valve
- 12. Resin tank
- 13. Control valve assembly

Model	RL-R30/M8A3 and M8B3
Tank Size	6" x 12"
Resin Volume	.165 f ³
Capacity	211 to 237 gal.
Salt Consumption	.75 to 1lb. (per regen)
Brine Tank	6.6 lbs.
Flow Rate	2.64 gpm.
Max Regen	5 to 7 Times
Inlet/ Outlet	G 1/2 / 1/4
Dimensions	20.5"H x13.8"W x 7.7"D
* All data based on testing with 11.7 gpg hardness	